



Anderson Group

3

HIGH PERFORMANCE MACHINING CENTERS

www.anderson.com.tw

GS Series

Linear Motor Technology in Woodworking Machinery



In recent years, clients have increasingly higher demand on precision, speed, and efficiency. Traditional woodworking machinery which uses a rotary servo motor with ball screw for planar moving processing is no longer reach their demand. For this reason, Anderson has devoted to the research of higher transmission system, linear motors, three years ago to provide linear motors with the best price-performance ratio for various woodworking machinery.

Linear motor technology, which developed by Anderson, be awarded with innovation technology in IWF 2016. It carried with CNC router and is featuring high travel speed along with X and Y-axis and precise gearing and positioning, which replaced the traditional motor and reached new standard of machinery high speed and accuracy.

The Challenger Awards acknowledged the most significant achievement and highest contribution in the woodworking machinery industry. The company that received this award is distinguished as "developing innovative technology in products, services, or manufacturing techniques that will advance the industry."



GS Series

Linear Motor Technology in Woodworking Machinery



Light barrier laser projection line, which increase machine operation safety

The Y-axis gantry moving speed of GS machine that couples with linear motor can reach 120 meters/min; the cutting speed of direct line can reach 60 meters/min. The overall high-speed movement is agile and powerful, unlike the rough feelings of movement in ball screws or racks. With faster moving speed of machine and the function of software fast drilling, the overall processing time of machine is reduced. It allows customers have more production in the same working time.



10-tool Carousel with PMM System
Various Boring Unit types With L Shape



Roller System for loading Panels



Automatic up-loading system

GS Series

Linear Motor Technology in Woodworking Machinery

Off-Loading Conveyor system

With Chip collection system. There is a standard dust extraction system located at the rear side of the conveyor system for cleaning the belt.

Manual-Labeling with Touch Screen

Operator can select any pattern displayed on the monitor to print out the required label.



MODEL		GS-612
STROKE	X AXIS	3900mm
	Y AXIS	2235mm
	Z AXIS	200mm
TABLE SIZE		3700x1900mm
VACCUM AREA		6
MAX.FEED SPEED	X AXIS	120m/min
	Y AXIS 380V/29Kw	120m/min
	Z AXIS	30m/min
NO.1 ATC HEAD	SPEED	1,000-24,000rpm
	SPINDEL	HSK-63F
	POWER	11Kw
	DRILL ROTATION SPEED	4800rpm
NO.2 MULTI-DRILL -10x7	SHANK OF DRILL	ø10mm
	POWER	2.2Kw
	SHANK OF ROUTER BIT	MAX.ø25mm
TOOL	NUMBER OF TOOLS	20
POWER		50A/415V/30Kw
AIR PRESSURE	HOS:3/4"	6kg/cm ²
	CONSUMPTION	500L/min
NC CONTROLLER		SYNTEC
DIMENSIONS	FLOOR AREA	15600X5500 mm
	HEIGHT	2500 mm
	WEIGHT	8500 kg

Auto Labeling System

It allows the operator to run the machine while the printer is labeling on the panel without stopping.



Auto up-loading in Labeling System

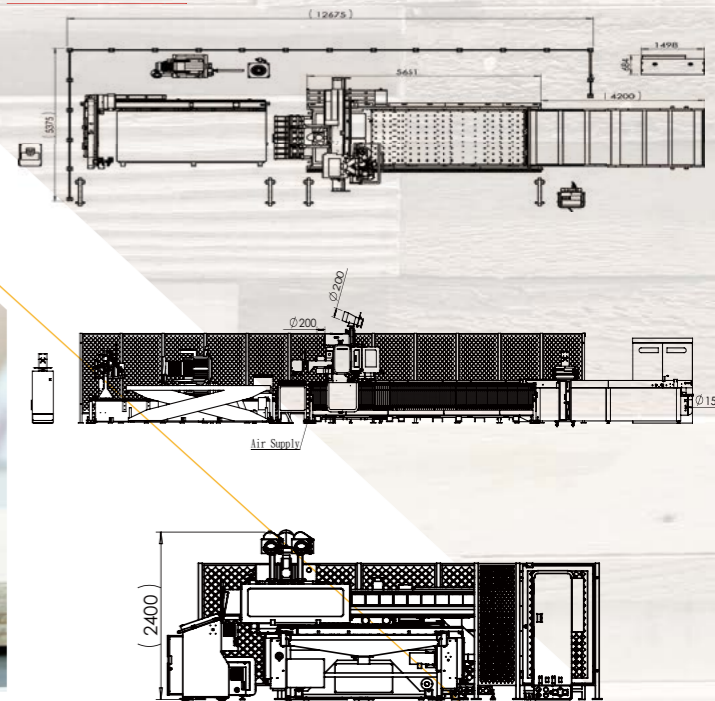

SPECTRA

The next generation of CNC Processing Center

Extremely Rigid Steel Base

The base is constructed of heavy gauge bar and tube. Critical alignment surfaces are machined to the highest tolerance. The design of the frame maximizes the machine stiffness and minimizes the machine vibration.

High Accuracy Servo Motors

All axes are controlled by high tolerance AC Servo motors. The AC Servo motors allow the machine to position with the highest positioning accuracy, as well as acceleration.



SPECTRA

The next generation of CNC Processing Center

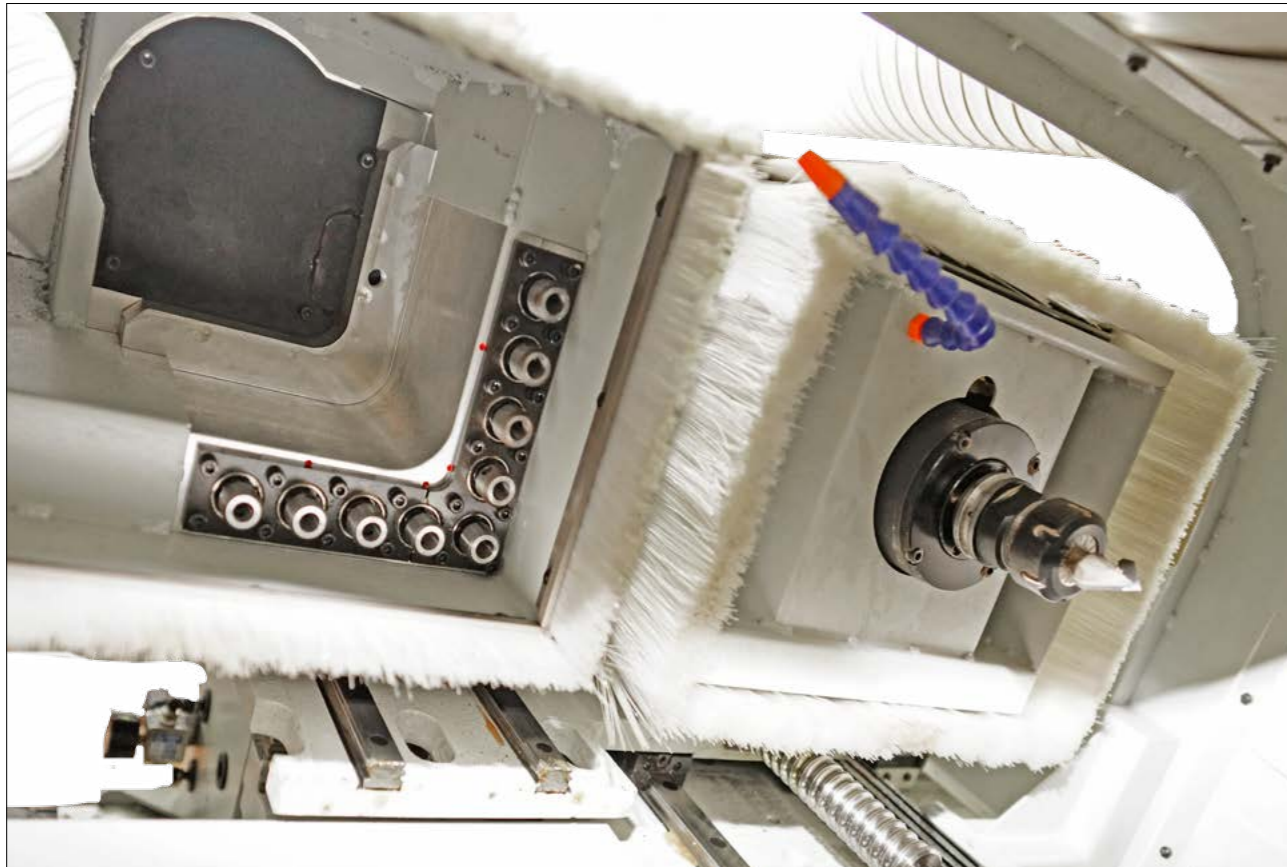

Machine Foundry Rigid construction with vacuum chamber. Standard spindle configuration is a 10 HP Air cooled plus line boring unit. High precision linear guide rails Installed on all axes. Phenolic Table Top With vacuum grid suitable for a variety of vacuum hold down possibilities from spoil-board, jigs to vacuum pods.

The diameter of Tool Touch Off device is 100mm. Movable Pedestal is with an adjustable joint of PC monitor for visually in different angles.

Z axis Ball Screw Diameter: 32 mm Pitch: 10 mm

Pop up pin for panel positioning



Automatic Tool Pick-up Station

For rapid tool changing, saving time throughout the machining cycle.

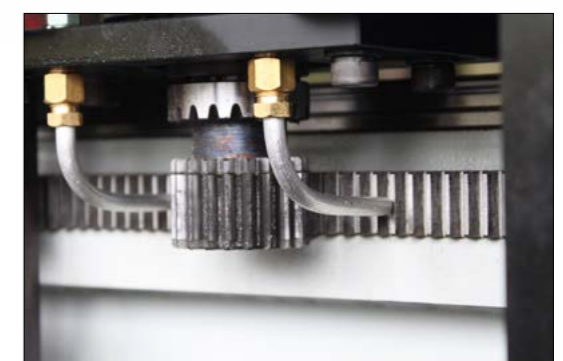

Air Nozzle device

It can keep the rack and pinion clean all the time.

SPECTRA

Working Area

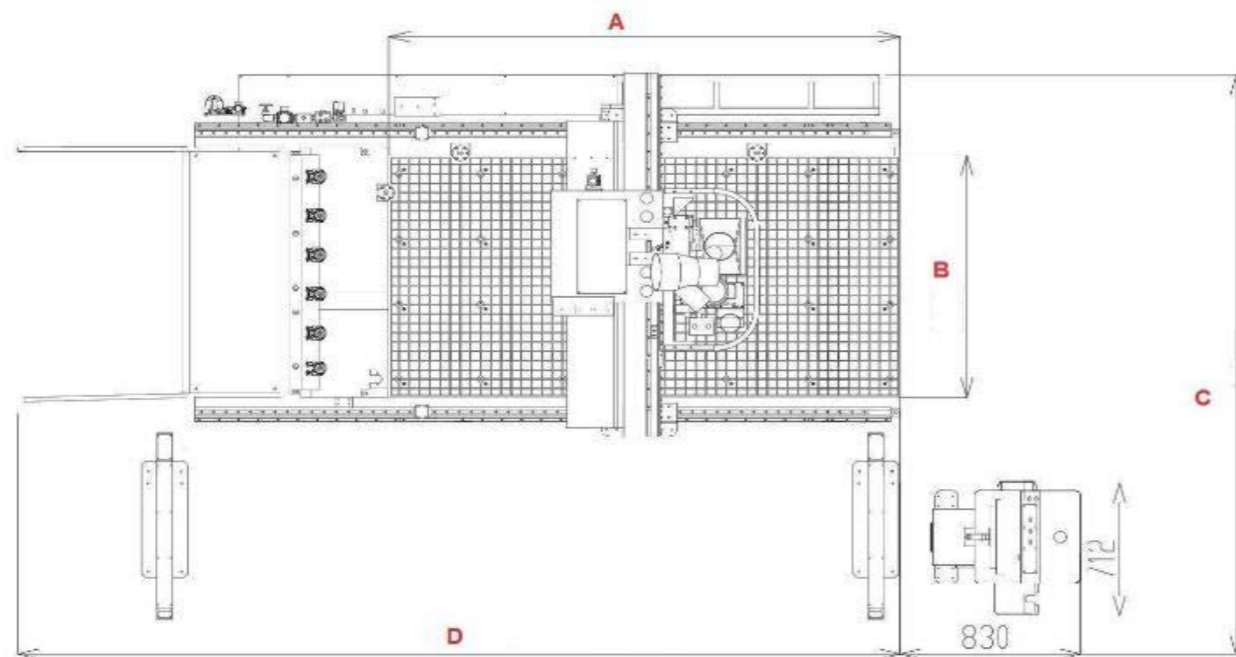

MODEL	A	B	C	D
SPECTRA 48	2500	1300	2950	4300
SPECTRA 510	3100	1600	3250	4900
SPECTRA 612	3700	1900	3800	6000

Unit:mm

SPECTRA

Technical Specification

MODEL		SPECTRA 48	SPECTRA 510	SPECTRA 612
NO. VACUUM ZONES		1	2	2
TABLE SIZE		2650X1300mm	3100X1600mm	3700X1900mm
STROKE	X-AXIS	2,500mm	3,100mm	3,700mm
	Y-AXIS	1,600mm	1,900mm	2,200mm
	Z-AXIS	200mm	200mm	200mm
DRIVEN SYSTEM	X		RACK & PINION	
	Y		BALLSCREW	
	Z		60 M/Min	
RAPID TRAVERSE	X		60 M/Min	
	Y		20 M/Min	
	Z		SK-30 /HSK-63F	
ROUTER SPINDLE	TYPE		10 HP	
	POWER		1,000 - 18,000 RPM	
	RPM		MAX @ 25mm	
SHANK DIAMETER	FOR ROUTER BIT		MAX @ 25mm	
AUTOMATIC PICK-UP STATION	ROTATION SPEED	6 POSITIONS	8 POSITIONS	8 POSITIONS
LINE BORING UNIT		V6 IN LINE/5 x 5 VERTICAL DRILLING		
NC CONTROLLER		SYNTEC		
WEIGHT		3,000 KGS	3,500 KGS	4,000 KGS
VACUUM PUMP	250 CBM/HR	1	1	2
DUST EXTRACTION FOR SPINDLE			STANDARD	
LIGHT BARRIERS			3 sets	
POP UP PIN			3	
TOUCH OFF DEVICE			STANDARD	
SAFETY HOOD FOR SPINDLE			STANDARD	
APPLICATION SOFTWARE			CAM PRO HYBRID NEST	
PUSHER			STANDARD	
WARRANTY			12 MONTHS	

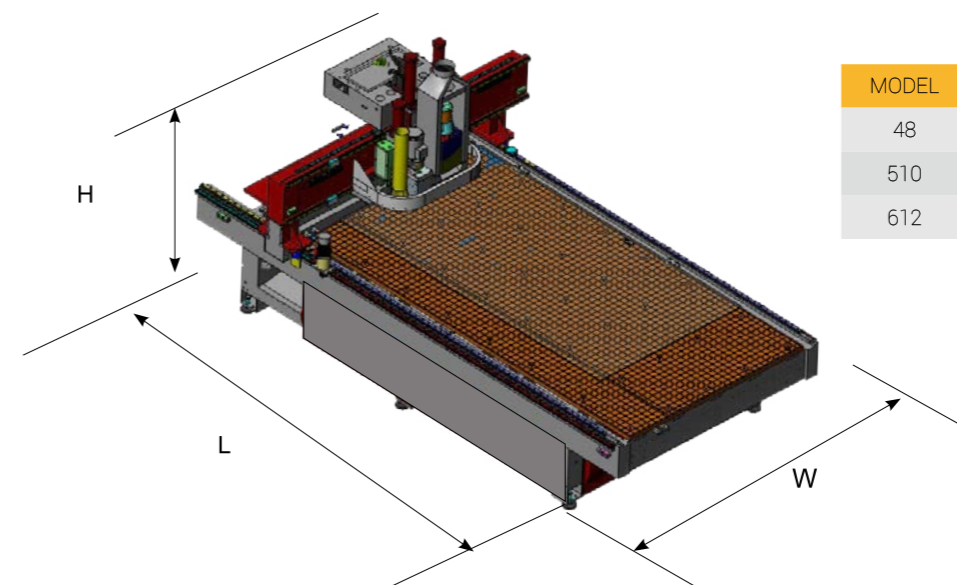

MODEL	L	W	H
48	3600	2700	2500
510	4500	3600	2500
612	5500	4000	2500

Unit:mm

Genesis EVO

The next generation of CNC Processing Center

Anderson has more than 40 years of global CNC engineering experience. During this period, Anderson has developed into a world leader of CNC processing equipment.

Anderson CNC routers can process wood, composites, MDF, Melamine board and other non-ferrous materials in high accuracy and high production applications.

The machine frame has industrial level bearings and a PC based controller that will allow for a quick installation of both the machine and the software.

The machine provides a steadfast platform for variety of CNC applications.

Primary Applicable Industries:

- Panel Industry
- Sign & Graphic
- Transformer Insulation
- Composites
- Thermo Plastic
- and other Non-ferrous materials



Genesis EVO

Fully automated CNC machining center with touchless loading and offloading capabilities

Why nesting?

- More customize cutting without board waste.
- Higher efficiency for processing.
- Vertical drill, labeling and cutting finished by serial processing.
- One person can operate two full line machine at once.

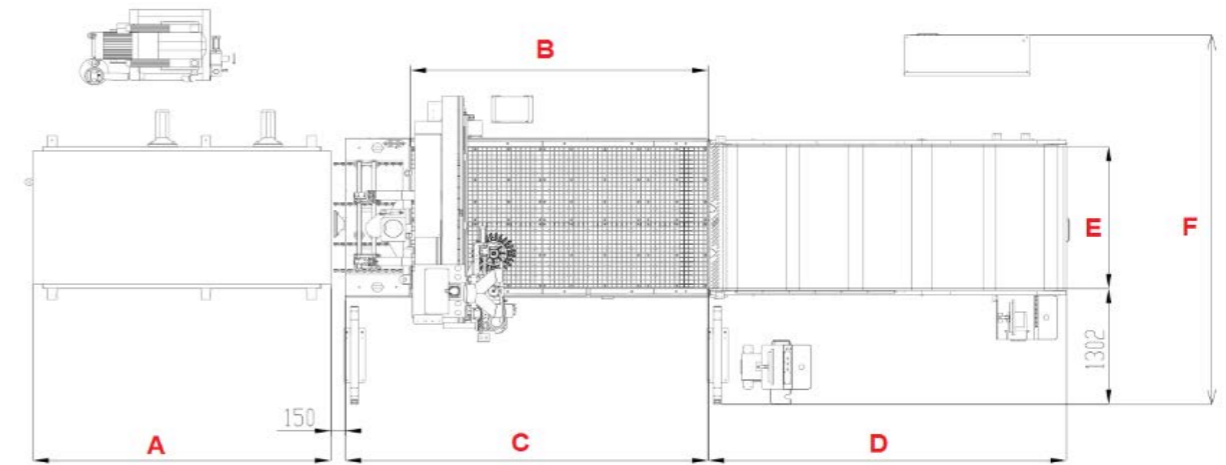

MODEL	A	B	C	D	E	F
Genesis EVO 49	2400	2700	3370	3324	1474	4134
Genesis EVO 510	3100	3100	3770	3924	1752	4034
Genesis EVO 612	3700	3700	4375	4314	2052	5320

Unit:mm



Tool Touch Off device

The diameter of this touch pad is 100mm.

Joint of PC Monitor

Movable Pedestal is with an adjustable joint of PC monitor for different angles.



Genesis EVO

The next generation of CNC Processing Center

Genesis EVO

Technical Specification

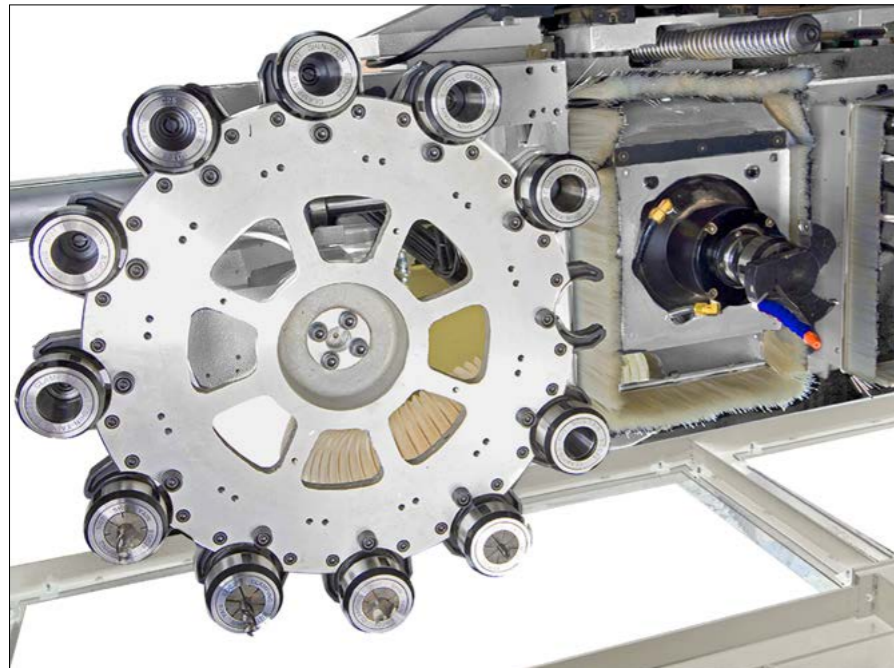

12-tool Carousel with PMM system



Various boring unit types with L shape



Roller System for loading panels



Pop Up Rail System for panel positioning and parts pushed off

MODEL		Genesis EVO 49	Genesis EVO 510	Genesis EVO 612
STROKE	X AXIS	2900mm	3300mm	3900mm
	Y AXIS	1700mm	2000mm	2300mm
	Z AXIS	200mm	200mm	200mm
TABLE SIZE		2700x1300mm	3100x1600mm	3700x1900mm
VACCUM AREA		1	2	4
MAX.FEED SPEED	X AXIS	80m/min		
	Y AXIS	80m/min		
	Z AXIS	30m/min		
NO.1 ATC HEAD	SPEED	1,000-24,000rpm		
	SPINDEL	HSK-63F		
	POWER	7.5 Kw/11Kw		
DRILL-UNIT	DRILL ROTATION SPEED	4800rpm		
	SHANK OF DRILL	ø10mm		
	POWER	1.5Kw		
TOOL	SHANK OF ROUTER BIT	MAX.ø25mm		
	NUMBER OF TOOLS	8	8/12	12
POWER		208/240/480V/24Kw65/55/27A		
AIR PRESSURE	HOS:3/4"	6kg/cm ²		
	CONSUMPTION	500L/min		
NC CONTROLER		SYNTEC		
WEIGHT		2200kg	3800kg	6500kg

MODEL	L	W	H
49	4300	4400	2500
510	7800	4500	2500
612	14000	5200	2500

Unit:mm

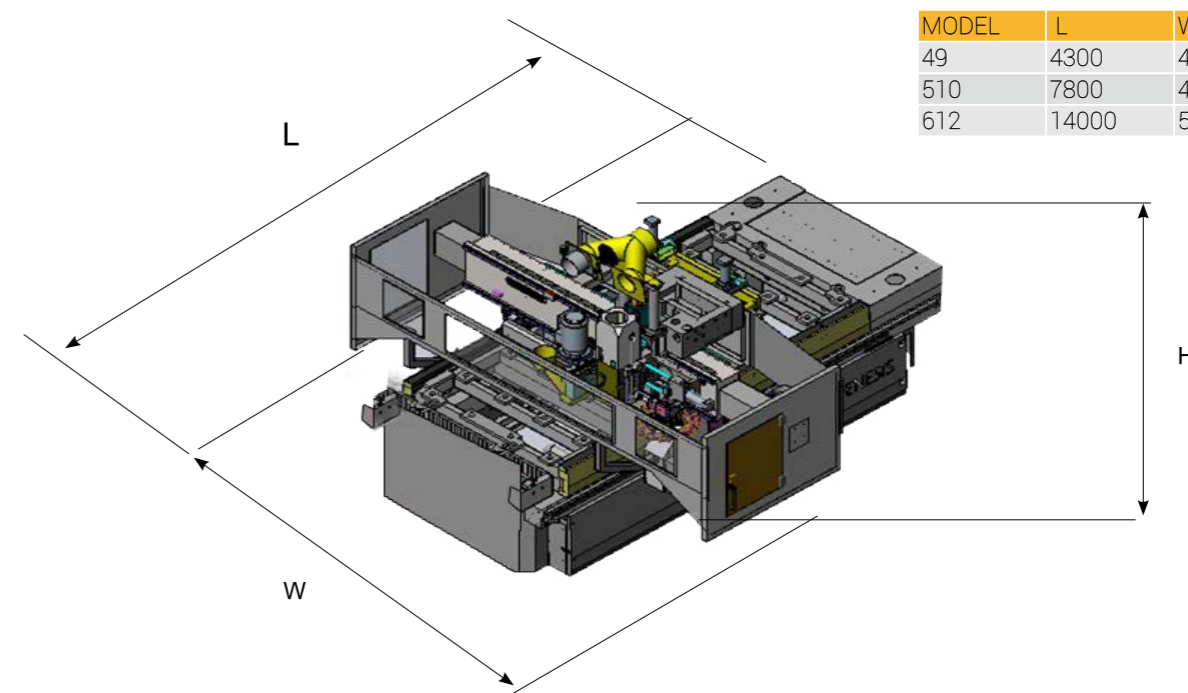

SELEXX

The next generation of CNC Processing Center

Anderson Routers are proven in the high production manufacturing industry. They are used in all facets of industry through the world, including Aerospace Technology, Woodworking Production, Plastics and Composite Materials Processing. Due to the solid construction, high quality components, machine characteristics the ANDI Selexx series offers the best price and quality ratio of any cost efficient CNC router on the market today.

Anderson SELEXX CNC Routers offers a first class CNC Machining centre. Selexx has been developed specifically to satisfy the client demanding the utmost in technical quality and reliability in a CNC Machining Centre within a cost effective investment.

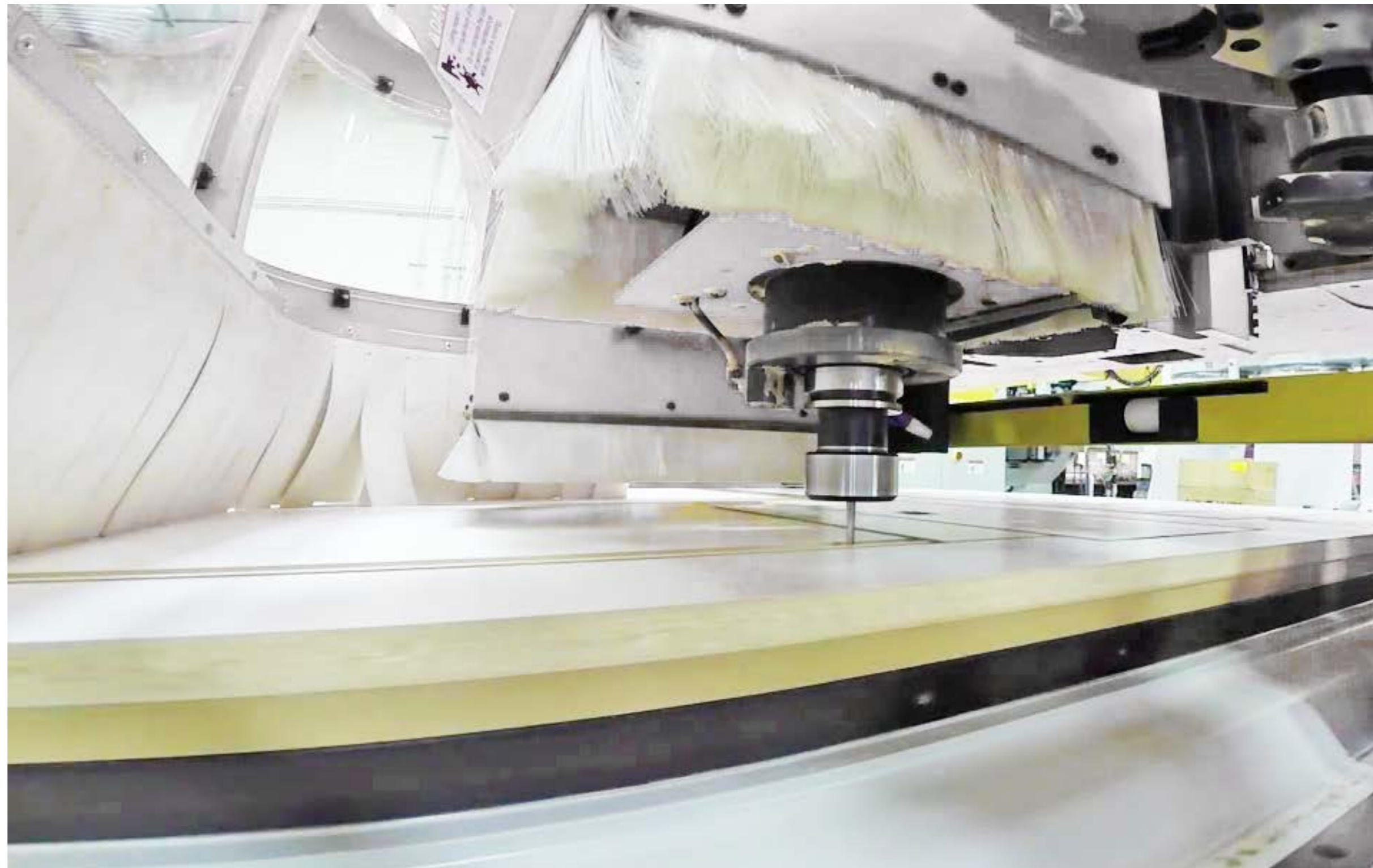

SELEXX

The next generation of CNC Processing Center

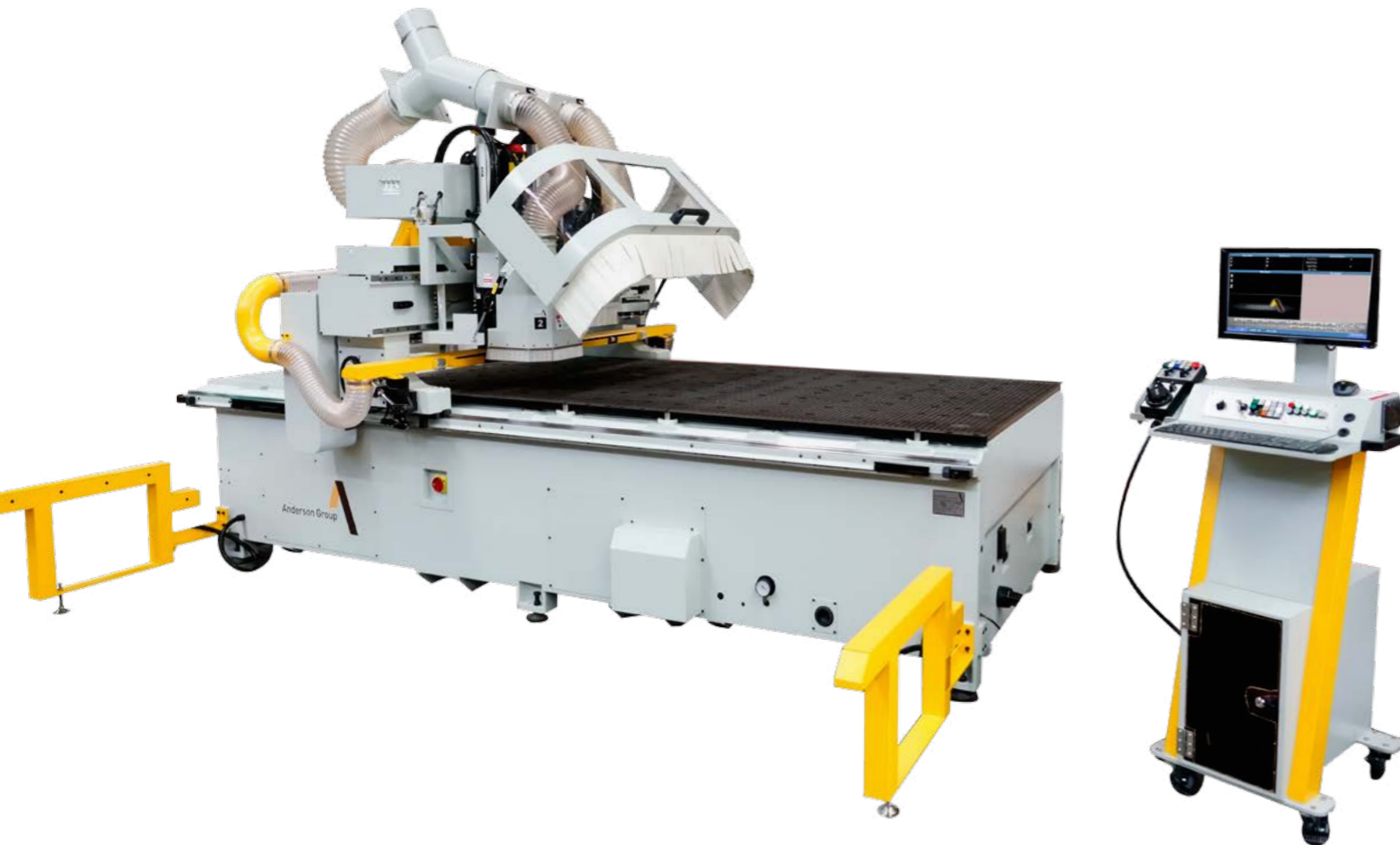

Automatic Unloading Pusher

Optional Pusher increases the machine productivity by up to 90%. At the completion of the machining cycle the pusher transports the completed nest of panels out of the working area allowing immediate loading of the next machining cycle.

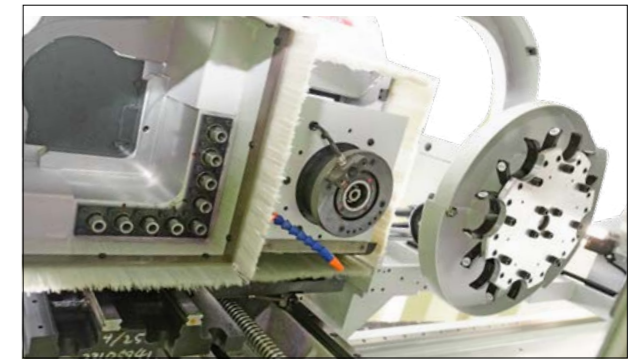

Working Spindle

Anderson Heavy Duty High Precision HSK 10hp Router with Rapid Automatic 8 position tool changer making light work of any type of routing or grooving operations. Boring Unit with 9 independent vertical drill spindles allows row hole and point to point drilling operation. Independent Grooving Saw and Horizontal Drilling Units available as an option.

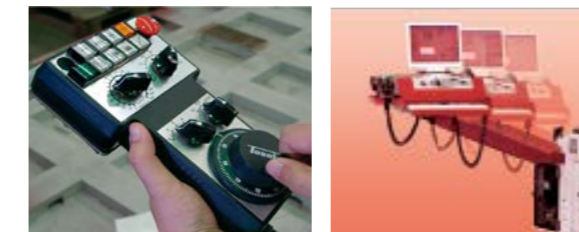

Handheld device

Handheld Device interface allows operator to jog the machine, perform system tests and run CNC programs from a remote computer system.

PC Front End Control

PC with Windows operating system allows network or USB interface for downloading of files and connection to other peripheral devices.

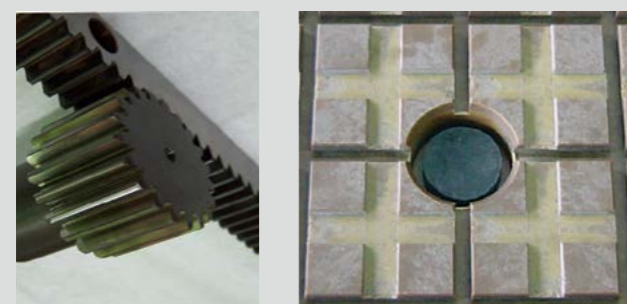

Induction hardened Rack and Pinion drive system

On the X axis ,each side with independent Servo Drive and zero backlash characteristics. High precision Ball Screw drive on the Y and Z axis.

Phenolic Table Top

with vacuum grid suitable for a variety of vacuum hold down possibilities from spoil-board jigs to vacuum pods

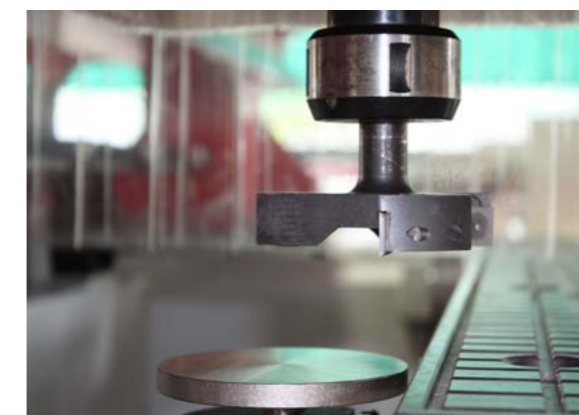

Tool Calibration Device

This unique touch-off device allows the cutting tools to be calibrated accurately, simply and safely, the control records the value automatically in to the tool offset file.



Tool Carousel

On board 8 position heavy duty tool carousel for rapid tool changing saving time throughout the machining cycle.

SELEXX

Fully automated CNC machining center with touchless loading and offloading capabilities

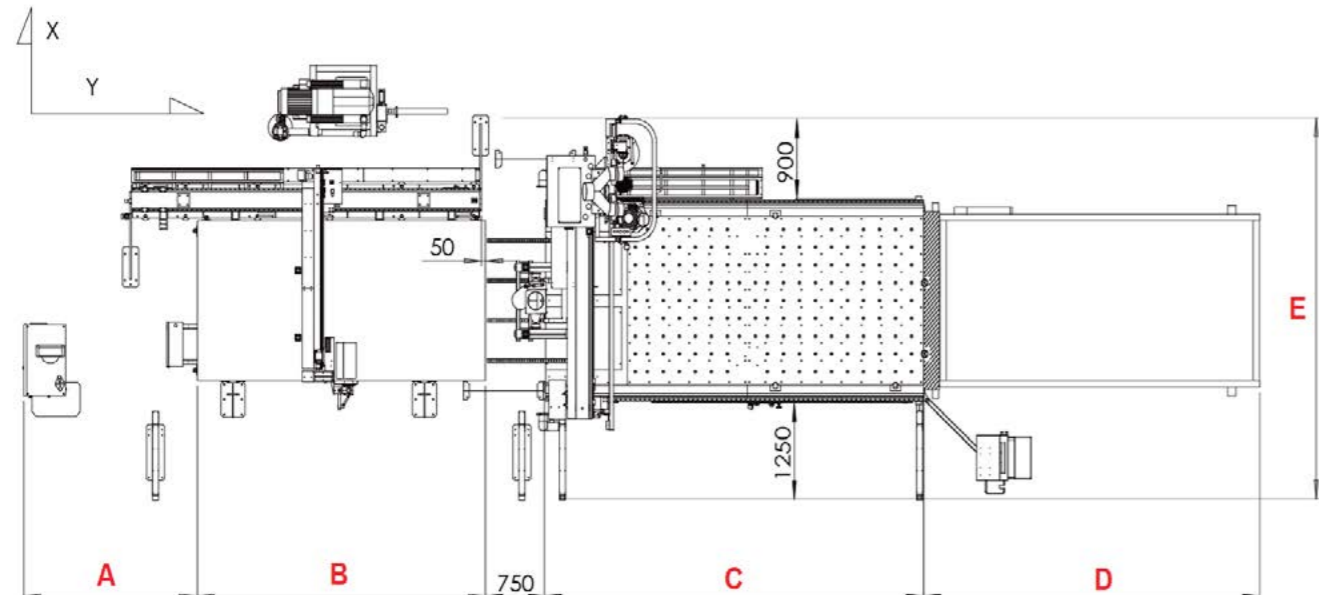

Working Area	A	B	C	D	E
SELEXX 3719 Full Line	2714	3600	4736	4200	4300
SELEXX 3722 Full Line	2714	3600	4736	4200	5200

Unit:mm

MODEL		SELEXX /2513	SELEXX /2519	SELEXX /3713	SELEXX /3719
STROKE	X AXIS	2630mm	2630mm	3900mm	3830mm
	Y AXIS	1720mm	2245mm	2300mm	2245mm
	Z AXIS	250mm			
TABLE SIZE		2500x1300mm	2500x1900mm	3700x1300mm	3700x1900mm
MAX.FEED SPEED	X AXIS	80m/min			
	Y AXIS	50m/min			
	Z AXIS	20m/min			
ROUTER SPINDLE	NO.1 SPINDLE	1			
	TOOL HOLDER SHANK	HSK-63F AIR COOLED			
	NUMBER OF TOOLS	8			
BORING BLOCK	SPEED	1,000-24,000rpm			
	NO.2 BLOCK	4800 RPM			
	ATC HEAD	7.5 KwX1			
MOTOR POWER	BORING	1.5 KwX1			
	VACUUM PUMP 250 BM/HR	5.5 KwX1			
		6kg/cm ²			
AIR PRESSURE		6kg/cm ²			
TOOL	SHANK OF ROUTER BIT	MAX.ø25mm			
	SHANK OF DRILL	ø10mm			
NC CONTROLER		ANDI-FANUC			
DIMENSIONS	FLOOR AREA	6000x4000mm	6000x4500mm	8000x4000mm	8000x4500mm
	HEIGHT	2450mm			
WEIGHT		3600kg	4500kg	4200kg	6500 kg
AIR CONSUMPTION		450 L/MIN			
DUST EXTRACTION CAPACITY FOR MAIN SPINDLE		2965 M ³ / HR			
TOTAL CONNECTED LOAD/RATES CURRENT		25 KW/47A			

STRATOS PRO

The next generation of CNC Processing Center

The STRATOS PRO is especially designed for manufactures who require high production and a flexible machine for their process needs. And good for both individual and nesting based parts machining.

Greatest versatility with excellent processing performance. Reliability and economy is our priority.

The helical rack & pinion drive allows fast and accurate positioning. Furthermore, this design is possible to extend the table dimensions in X-direction to match customer's needs.

Dual vacuum zones and mirror function. The machine has one set of 90 mm locating pop-up pins inside the working table. The grooved table surface is from HPL phenolic providing for multiple fixturing and clamping systems.



STRATOS PRO

The next generation of CNC Processing Center



PC Front

The ANDERSON-Fanuc controller with PC Front-end is the result of a consequent continuous development process for the increasing demands of the woodworking industry.

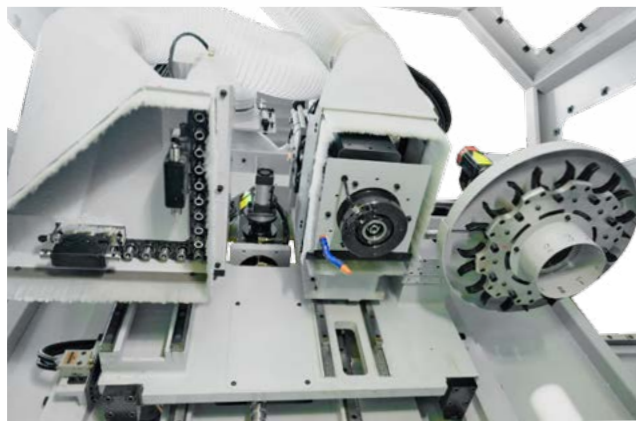

The automatic tool change system provides 10 positions as standard and is available for HSK tool holders.



The boring unit is equipped with 16 vertical spindles and two 2-way-spindle unit for horizontal drilling.



Hand-held device

The Hand-held device is designed for easier machine operation.

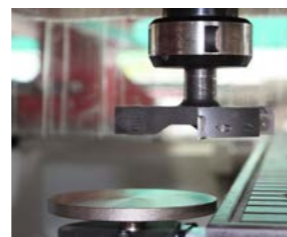

Tool Touch Off device

The diameter of this touch pad is 100mm.



Anderson has developed a high standard of heavy-duty spindle technology, spindle cones fit all commonly available tooling systems. In addition, the Anderson spindle is equipped with standard cooling systems and are available with optional water cooling systems.

This Spindles are available for the STRATOS series with a 360o C-axis to partner with standard automatic tool changers.



The circle interpolation of this new generation was once again improved. The i-series is equipped as standard with a high speed serial bus (HSSB) to operate with an CAD/CAM programming system.

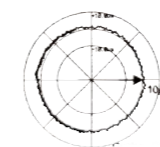

SERVO HRV Control



STRATOS Series

The next generation of CNC Processing Center

STRATOS

Technical Specification

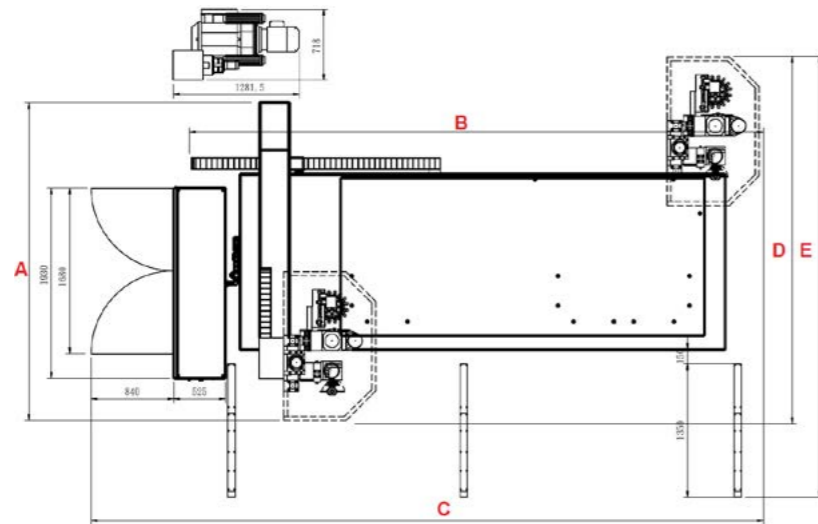

Model	A	B	C	D	E
STRATOS PRO 3719	3224	5840	6840	3725	4470
STRATOS PRO 3722	4424	5840	6840	4925	5670

Unit:mm

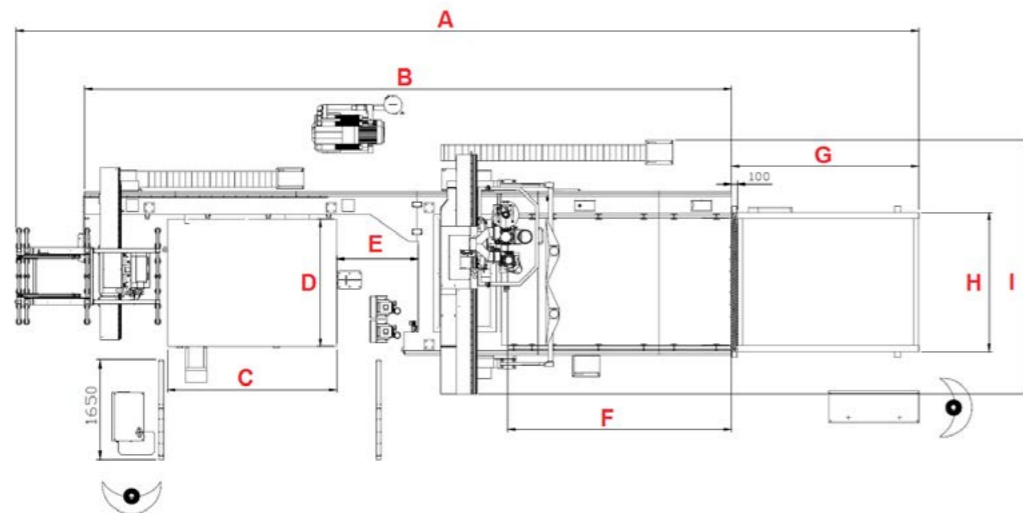

STRATOS FL	A	B	C	D	E	F	G	H	I
2821	14937	10400	2800	2100	1350	3700	3100	2300	4201
3719	21450	15850	3600	1800	1265	4700	4200	2100	6165
3722	21450	15850	3700	2200	1265	4700	4200	2200	6265

Unit:mm



MODEL		STRATOS SUP	STRATOS PRO	STRATOS PRO XL
STROKE	X AXIS	3,400mm	3,900mm	3,900mm
	Y AXIS	2,180mm	2,180mm	2,100mm
	Z AXIS	250mm	350mm	350mm
TABLE SIZE		3,200x1,600mm	3,700x1,600mm	3,700x2,100mm
VACCUM AREA		2		
MAX.FEED SPEED	X AXIS	50m/min	80m/min	80m/min
	Y AXIS	50m/min	80m/min	45m/min
	Z AXIS	12m/min	30m/min	30m/min
NO.1 ATC HEAD	SPEED	1,000-24,000rpm		
	SPINDEL	HSK-63F		
	POWER	7.5Kw		
NO.2 MULTI-DRILL	DRILL ROTATION SPEED	4800rpm		
(5 X 5 VERTICAL)	SHANK OF DRILL	ø10mm		
	POWER	1.5Kw		
TOOL	SHANK OF ROUTER BIT	MAX.ø25mm		
	NUMBER OF TOOLS	8		
POWER		380V/30Kw /56A		
AIR PRES-SURE	HOS:3/4"	6kg/cm2		
	CONSUMPTION	330L/min		
NC CONTROL-ER		ANDI-FANUC		
DIMENSIONS	FLOOR AREA	6,340x3,750mm	6,840x3,750mm	6,480x4,970mm
	HEIGHT	2,800mm	2,950mm	2,950mm
	WEIGHT	5,500kg	5,500kg	6,000kg

Option Device



Hydraulic Lifting system
Loading for panels up to 2 tons

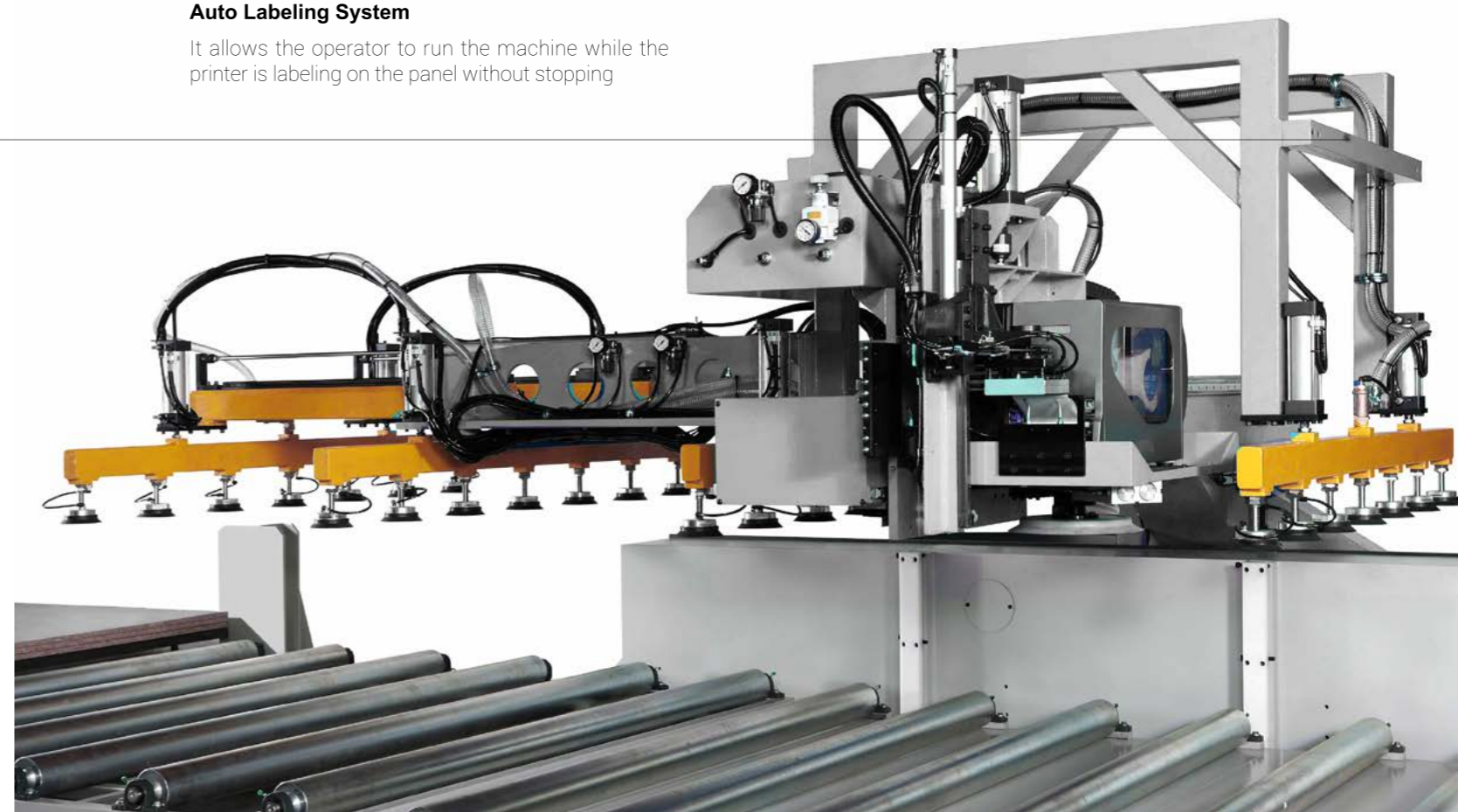

Auto Labeling System

It allows the operator to run the machine while the printer is labeling on the panel without stopping



Off-Loading Conveyor system

With Chip collection system. There is a standard dust extraction system located at the rear side of the conveyor system for cleaning the belt.

Manual-Labeling with Touch Screen

Operator can select any pattern displayed on the monitor to print out the required label.

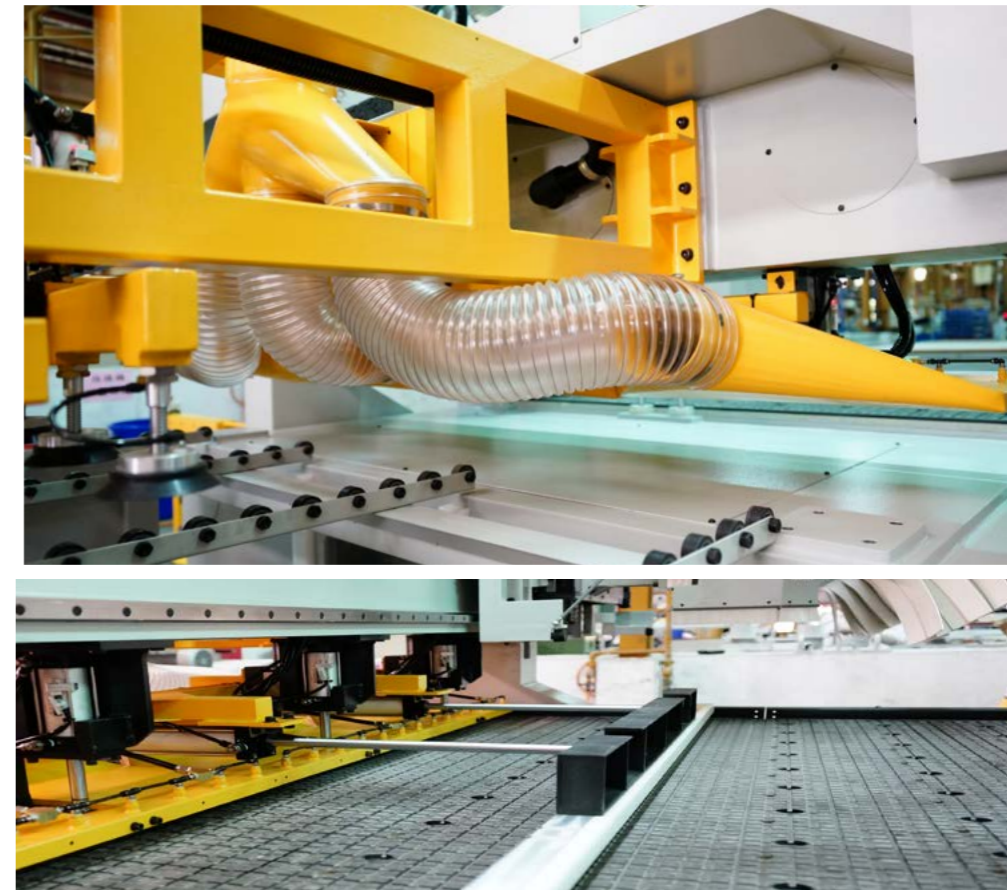
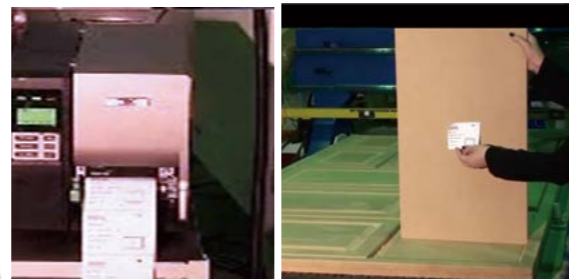

Pusher device with dust extraction

It also can use off-loading & positioning.

Software **AGMVP**

Smart Platform - Transferring data through a web link device

Anderson have been developed it's own AGMVP the Human-Machine Interface, through the new system integration, the AGMVP did simplify the original complicated CNC operation steps. Operators can be familiar with the operation mode and online production within a short period of time, and use this system as a smart machine interface.

The new AGMVP included the maintenance of machinery, current monitoring, spindle temperature monitoring, drills life management, tool life management and other relative parameters were allowed on opening for external system, helping customers build their own smart, intelligent production facility.





Anderson Industrial Corp.

Head Office

5F., No. 88, Sec. 6, Zhongshan N. Rd., Shilin Dist., Taipei City 11155, Taiwan

T +886-2-2837 6866 F +886-2-2832 0866

Miao-Li Factory

No.1498, Zhonghua Rd., Houlong Township, Miaoli County 35651, Taiwan

T +886-37-726876 F +886-37-727727

service@anderson.com.tw